

cartero

DESIGNED FOR MORE

impel is-2

OWNER'S
HANDBOOK

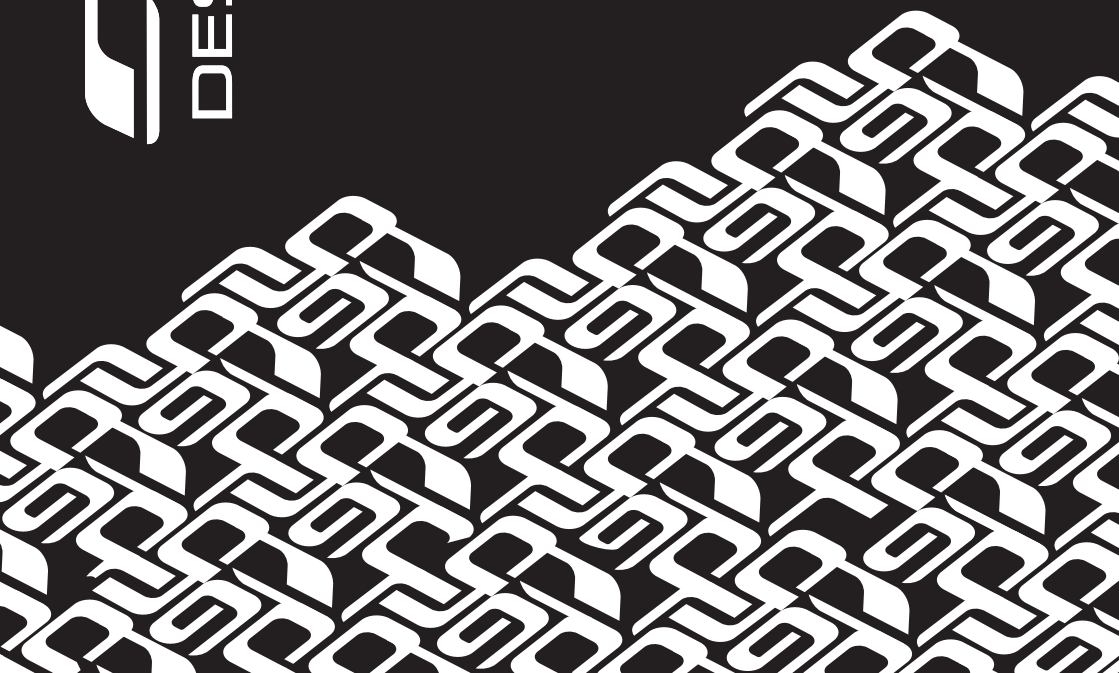
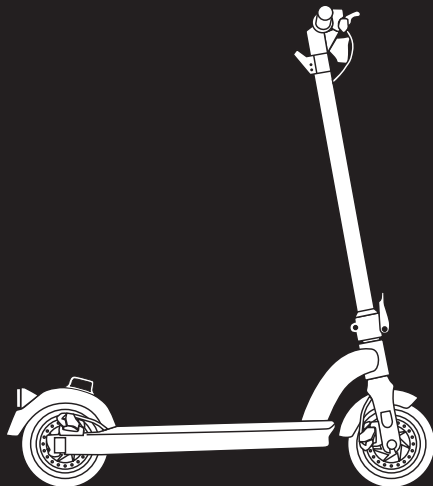

Please Read Before Use



Before any use, consult the legislation in force in your country.



Always wear a helmet and other appropriate protective equipment.



Ensure your battery is fully charged before driving.



Observe all road markings, signs and traffic regulations. Ensure you are always visible to others.



Watch for pedestrians and other road users.



Your Carrera impel is-1 scooter is not suitable for use in rainy weather: You may slip and severely harm yourself.



Do not use the scooter when under the influence of medication or alcohol.

Congratulations On Your Purchase Of This Electric Scooter!

- This manual will provide you with the information you need to use, adjust, and maintain your electric scooter properly.
- Take the time to carefully read and keep these instructions for future use. This manual contains important instructions for
 - Safety and care.
- It is the responsibility of the user to read this manual and to follow these instructions before using the product.
- It is important to heed all warnings.
- Failing to follow these instructions exposes you to the risk of improper use, prematurely wearing certain components which may result in a fall or accident.
- In the event that an original part shows a manufacturing defect during its warranty period, we will replace it. The warranty period for electric scooters is 2 years under condition of maintenance.

This warranty does not cover the cost of labour or transportation. The company cannot be held liable for damages out of the ordinary or due to a combined set of circumstances. This warranty is only valid for the original purchaser of the product with proof of purchase to support their claim. This warranty applies only to defective components and does not cover normal wear and tear, damages caused by accidents, improper use, excessive loads, improper assembly or maintenance, and any other object not intended for use with the electric scooter.

- No electric scooter will last forever and no claim will be accepted for damages caused by improper use, as part of competitions, stunts, ramp jumping or similar activities. Your rights will not be affected. The company reserves the right to change or modify any specifications without notice. All information and specifications in this manual are correct at the time of printing.
- Your electric scooter has been carefully designed and manufactured in accordance with the requirements of current European standards.
- Do not dispose of the electric scooter as household waste. For more information about battery recycling, contact your local authority, your local waste disposal centre or the point of sale where you purchased this product.

Conditions Of Use Of This Electric Scooter

At the time of writing it is illegal to use an e-scooter on public roads, pavements, cycle lanes or bridleways. You can use an e-scooter on private land, where the owner has given permission. Your electric scooter is intended for people over 14 years old. In the event that the electric scooter is used by a child, it is the parents' responsibility to ensure that the child is able to use the electric scooter safely. Your electric scooter is not intended for use on unpaved or poorly maintained roads. It is not designed for "off-road" use or competition. Failure to comply with these warnings may result in a fall or accident and cause premature and potentially irreversible damage to your electric scooter.

Carrera impel is-2 is not suitable for use by pregnant women or persons under 14 years of age.

This device may be operated by children ages 14 and up under adult supervision, and by people with limited physical, sensory or mental capacities or lacking knowledge or experience, provided they are properly supervised or receive instructions for using the device safely, and that they understand the risks incurred.

Your electric scooter has an electric motor located in the rear wheel which is activated when the scooter is started and the throttle lever is pressed. The electric motor stops as soon as one of the two brake levers is actuated or when the speed exceeds 25 km/h [15.5 mile/h]. It will resume working automatically below 23 km/h [14.3 mile/h].

The electric scooter must be properly maintained according to the instructions contained in this manual. Periodically check that the Carrera impel is-2 is in good condition, read this manual carefully and make sure that you have understood all the product information before using it.

Table Of Contents

A. Product Overview	4
I. About the Carrera impel is-2	4
II. Package contents	4
III. Carrera impel is-2 description	5
B. First Use And Setting Up	5
I. Setting up the safety features	5
1. Lighting	5
2. Bell	5
3. Helmet use	6
4. Appropriate footwear	6
II. Unpacking and assembling the scooter	6
III. Folding and unfolding the scooter	6
IV. Braking	7
1. Adjusting the mechanical disc bakes	7
2. Changing the brake pads	8
C. How To Use Your Carrera impel is-2	8
I. Display interface	9
II. Electronic locking of the scooter	9
III. Control buttons	10
D. Error Codes	10
I. Using the anti-theft device	10
E. Instructions For Use	11
I. User weight limit	12
II. Maximum travel distance	12
F. Cruise Control	12
G. Speed Alarm	13
H. Using the Charger	13
I. Charging Procedure	14
J. Battery	15
I. Battery life	15
II. Warning, precautions	15
III. Battery service life	16
IV. Using the battery	16
K. Recycling	17
L. Cleaning, Maintenance And Storage	17
I. Cleaning	17
II. Maintenance	17
III. Storage	18
M. Technical Specifications	18
N. Scope of Warranty	18



Warning: As with any mechanical component, a vehicle is subject to high stress and wear and tear. Different materials and components may react differently to wear or fatigue. If a component's life expectancy is exceeded, it may fail suddenly and cause injury to the user. Cracks, scratches and discolouration in high-stress areas indicate that the component has exceeded its life expectancy and should be replaced.

Recommendation: Safe use

Before using your electric scooter, make sure it is in good working order.

In particular, check the following:

- Nuts, screws, clamping levers, tightening of components
- Brakes are in working order
- Handlebars are correctly attached to the stem
- Wheels are properly tightened and attached to the frame and the fork
- Tyres are in good condition and are properly inflated
- The reflectors are correctly positioned.
- Lights are in working order



RECOMMENDATION: Your electric scooter should be serviced every 6 months by a professional to ensure it is in good working order and safe to use. It is the user's responsibility to ensure that all components are in good working order before use.

Choose a safe place, away from traffic, to familiarise yourself with your new electric scooter. The motor may start in a forceful manner, check that your handlebars are straight and that the path is clear. Getting used to the product requires an adjustment period. To avoid a serious accident during the first few months:

Make sure you are in good health before getting on your scooter.

In case of unusual weather conditions (rain, snow, etc) proceed with care and adjust your speed and reactions accordingly.

The user must comply with the requirements of national regulations when using the electric scooter on public roads (for example, lighting and signalling).

Halfords declines all responsibility if the user of the electric scooter does not comply with the regulations in force.



Warning: You acknowledge that you are responsible for any loss, injury or damage caused by a failure to comply with the above instructions and that this will automatically void the warranty.

A. Product Overview

I. About The Carrera impel is-2

The Carrera impel is-2 is a two-wheeled electric scooter.

II. Package Contents

- Carrera impel is-2 Electric Scooter (unassembled handlebars)
- Charger
- User manual
- 3mm hex key
- 4 screws for the stem

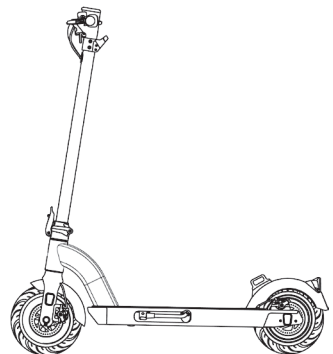



Warning: You must keep the packaging of your Carrera impel is-2. It will be easier for you to return your electric scooter in its original packaging if you require after-sales service.

III. Carrera impel is-2 Description

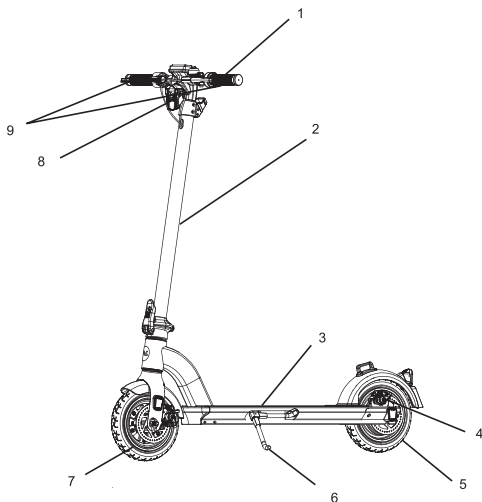

1. Handlebars
2. Stem
3. Deck
4. Rear disc brake
5. Hub motor
6. Kickstand
7. Front wheel
8. Headlight
9. Front and rear brake levers

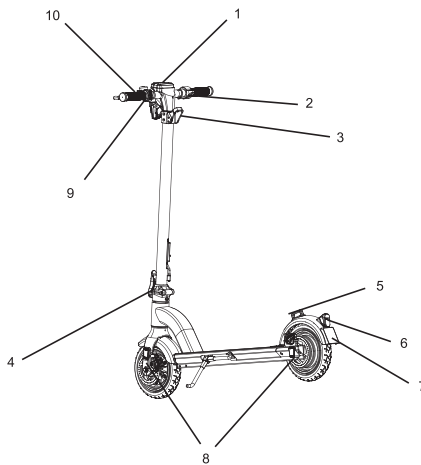

1. Display
2. Throttle lever
3. Head unit clip
4. Folding mechanism
5. Head unit mount
6. Taillight
7. Space for license plate (if required by local regulations / authorities)
8. Side reflectors
9. Control buttons
10. Bell

B. First Use And Setting Up

I. Setting up the safety features

1. Lighting

Lighting is provided on the scooter: it consists of two reflectors (a white one included in the headlight and a red one attached to the rear mudguard), a headlight, a taillight, and four other orange reflectors on the sides.

The lighting system is a safety feature of your electric scooter. It must be in good working order. Ensure that your lighting system is working properly before you set off.

The front and rear lights are powered by the scooter's battery.

2. Bell

A bell is installed on your handlebars. It will allow you to be heard from a distance of 50m.

The bell is a safety feature of your scooter, it must be installed on your handlebars.

3. Helmet use

For safe use, helmet use is strongly recommended. It guarantees a reduction in head trauma in the event of a fall.

4. Appropriate footwear

For safe use, shoes must be worn at all times.

For more information, please consult your place of purchase.

II. Unpacking and assembling the scooter

1. Open the box and take out all the parts (do not throw away the packaging, you will need it if you need to return the product).
2. Lift the stem while holding the handlebars.
3. Lift the folding lever on the folding mechanism and make sure it is securely locked.
4. Insert the handlebars onto the stem using the positioning guides and the positioning pin to route the cable.
5. Place the holes of the head unit clip opposite the holes in the stem and handlebars.
6. Tighten the two screws on each side using the 3 mm hex key provided.
7. Pull the brake lever and insert the head of the brake cable into the brake lever bracket.
8. Thread the cable through the slot in the brake lever until the sheath fits into the stop on the brake lever. You must pull on the sheath to perform this operation.
9. Check the brake operation by actuating the brake lever. The brake calliper must apply pressure to the rotor to prevent the wheel from turning.
10. Carry out steps 7, 8 and 9 for each brake lever. Verify that the right lever operates the brake system for the front wheel and that the left lever operates the rear brake system.

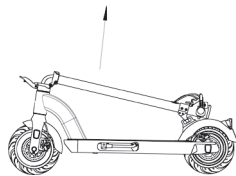

III. Folding and unfolding the scooter

To unfold the scooter:

- Unfold the stem:
 - Press the side of the head unit clip to open and release it from the head unit mount .
 - Pull the head unit clip out of the head unit mount.
 - Lift the stem into a vertical position.
 - Lift the folding mechanism lever until the stem safety locks and make sure it is securely locked.



To fold the scooter:

- Lower the stem:
 - Lower the stem folding lever by lifting the safety hook.
 - Lower the stem until it sits parallel to the deck.
 - Press the side of the head unit clip to engage it in the head unit mount.

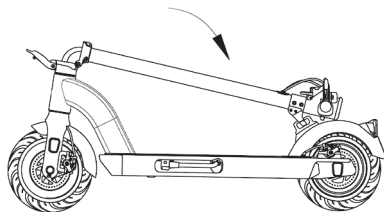
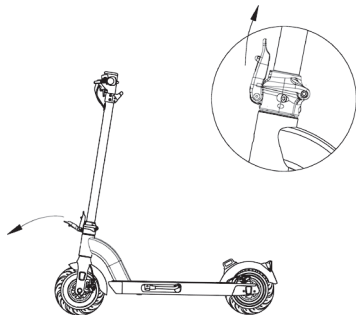

WARNING

Warning: The head unit clip is part of the folding system and must not be used to carry luggage.

Attaching any load to the handlebars will affect the stability of the electric scooter.

IV. Braking

The Carrera impel is-2 electric scooter features both front and rear disc brakes, these brakes are very efficient but must be well controlled. Therefore, please pay close attention to the following points:

- To slow down, simply release the throttle.
- To brake, do not press the brake lever too hard. Sudden braking can lead to a loss of balance and fall; press down the brake lever gradually to slow down safely.
- Do not tighten your brake cable more than necessary at the brake calliper. The front or rear wheel must not lock during emergency braking and cause a fall.
- Never touch the brake disc with your fingers after using the brake system, as you might burn yourself.
- Before each use, ensure the front and rear brakes are in perfect working order.
- The left lever activates the rear brake, the right lever activates the front brake.
- The brake lever must not come into contact with the handlebar and the sheaths must not be bent at a sharp angle so that the cables slide with minimal friction. Damaged, frayed or rusty cables must be replaced immediately.



WARNING:

In case of rain or wet weather, braking distances are extended. In such situation, braking must be anticipated.

WARNING

- When cornering and braking, the handlebars can have a negative influence on the rider's response time.

1. Adjusting the mechanical disc brakes

If your brakes don't work correctly please consult your local retailer for assistance.

- The brake pads exert pressure on a disc attached to the wheel hub. The pressure intensity is controlled by a brake lever via a cable. Do not actuate the brake lever when the wheel is detached from the frame or fork.
- If the brake is too tight or too loose, the brake cable must be adjusted to align the calliper with the brake disc.
- To align the mechanical disc brake calliper, loosen the fastening screws of the brake calliper bracket. Brake with the corresponding brake lever (the brake calliper is positioned correctly) and hold the brake lever in this position while tightening the fastening screws of the calliper bracket.
- Check that the inner pad (inside the wheel) is 0.2 - 0.4 mm from the disc. If this is not enough, tighten the pad positioning screw until there is a 0.2 - 0.4 mm gap between the pad and the disc.
- To adjust the outer pad (outside the wheel), simply change the brake cable tension to achieve a gap of 0.2 - 0.4 mm at the calliper or brake lever level.
- Never spray oil or any other lubricant onto the disc or pads. If this happens, the pads and disc should be degreased or replaced.
- Check the alignment of the brake pads by turning the wheel. You can now set off.
- Discs: Your scooter is equipped with 8.5-inch diameter discs.
- A nut and locknut system on the brake calliper allows you to adjust the cable tension and therefore the brake force, which will vary over time according to the wear of the brake pads.
- Brake pads are standard, replace them when they no longer have a friction component.

2. Changing the brake pads

Remove the wheel and remove the worn brake pads from the brake calliper. Position the new pads in the calliper so that the braking surfaces are in contact. Do not touch the braking surfaces. Insert the brake pads one after the other into the brake calliper.

If your brakes don't work correctly please consult your local retailer for assistance.

C. How to use your Carrera impel is-2

- **Step 1:** Check that the silicone cap covers the charging connector and that your product is not damaged.

- **Step 2:** Unfold the scooter as recommended in section "III. Folding and unfolding the scooter" and press the "On/Off" button. Enter the electronic lock code as described in section C.II, "Electronic locking of the scooter".

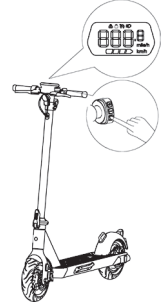

- **Step 3:** Once the scooter is switched on, check that the stand is folded up, put one foot on the board and start gaining forward momentum by pushing on the ground with the other foot, without using the throttle.

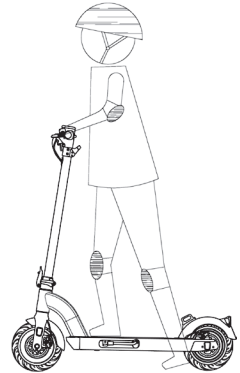

- **Step 4:** You must reach a speed of 3 km/h [1.9 mile/h] to be able to use the throttle and switch to electric mode. To accelerate, use the trigger or throttle lever near your right hand. Once in motion, you can adjust the speed ratio using the "+" or "-" control button.

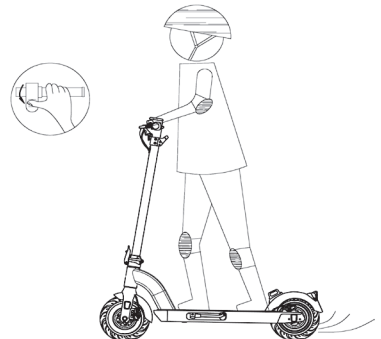

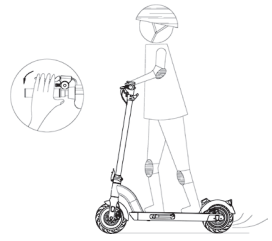

- **Step 5:** To brake, release the trigger or throttle lever and pull the brake levers.

- **Step 6:** Once your ride is complete, press and hold the On/Off button for 3 seconds to turn the scooter off.

IMPORTANT: To avert any danger, sharp turns should always be avoided when travelling at high speed. Keep your body balanced when turning to avoid falling over due to high speeds or a shifting centre of gravity.

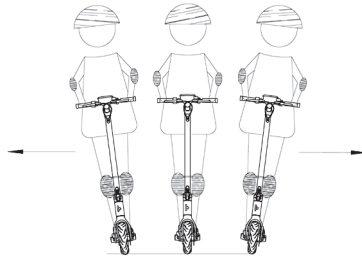

Ideal position for safe riding.

I. Display interface

The control screen, located on the handlebars, shows you the status of the scooter, its speed, the battery charge level, the front and rear lights and any error codes. It also allows you to set and enter the electronic lock code.

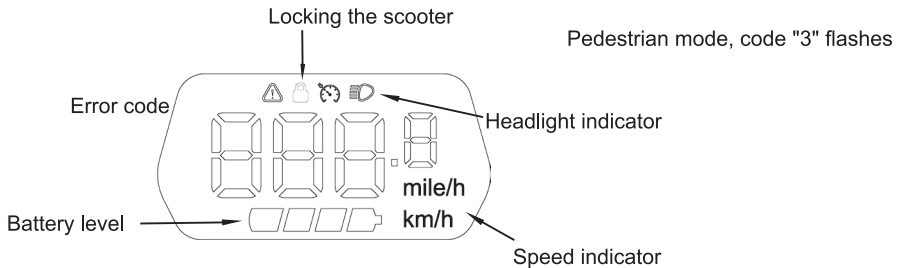

II. Electronic locking of the scooter

By default, the scooter is equipped with an electronic locking system that prevents the scooter from being switched on. When the power button is pressed, the control screen beeps and requires the unlock code to be entered. The default code is 000. If you attempt to move the scooter without entering the code, the brakes will be activated, the front and rear lights will flash and a continuous beep will sound.



Caution, this does not prevent the scooter from being physically stolen. For this purpose, use the built-in anti-theft device (see D.I.).

Entering the code to unlock the scooter

1. Hold the "On/Off" button for 3 seconds to switch the scooter on.
2. Enter the code using the buttons on the control panel.
3. The cursor will move to the first digit of the code - increase or decrease its value using the "+" and "-" buttons. Briefly press the "On/Off" button to confirm and move to the next digit.
4. Briefly press the "On/Off" button twice to confirm the code entry.

Activating the lock code

- Hold the "On/Off" button for 3 seconds to switch the scooter on.
- Simultaneously press and hold the "On/Off" and "+" buttons for 5 seconds to **activate/deactivate** the code lock feature.

Changing the scooter's lock code

- Hold the "On/Off" button for 3 seconds to switch the scooter on.
- Simultaneously press and hold the "On/Off" and "-" buttons for 10 seconds to **reset** the lock code.
- The cursor will move to the first digit of the code - increase or decrease its value using the "+" and "-" buttons. Briefly press the "On/Off" button to confirm and move to the next digit.
- Briefly press the "On/Off" button twice to confirm the new code.

III. Control buttons

1. The control button panel is located on the left side of the handlebars
2. **Switching on:** Briefly press the **"On/Off" button** to switch on the scooter.
3. **Switching off:** Press and hold the **"On/Off" button** for 3 seconds to switch off the scooter.
4. **Lights:** Press and hold the **"+" button** for 2 seconds to turn on/off the headlight and taillight.
5. **Speed modes:** Once moving, press the **"+" or "-" button** to switch speed modes.
 - Speed mode 1: 6 km/h [3.7 mile/h] max speed
 - Speed mode 2: 12 km/h [7.5 mile/h] max speed
 - Speed mode 3: 18 km/h [11.2 mile/h] max speed
 - Speed mode 4: 25 km/h [15.5 mile/h] max speed
6. **Pedestrian mode:** Press and hold the **"-" button** for 3 seconds to enable the pedestrian mode (speed limited to 3 km/h [1.9 mile/h]). On the display, the number "6" blinks and the taillight flashes every 3 seconds.

Do not press the throttle lever at the same time as the pedestrian mode to prevent the electric scooter from starting up using the selected speed mode.

The pedestrian mode is used when the user must walk beside the scooter. The pedestrian mode reduces the effort required by ensuring a speed of 3 km/h [1.9 mile/h].

D. Error codes

If a malfunction occurs while using your Carrera impel is-2, simultaneously press and hold the "On/Off" and "-" buttons for one second, one of the following error codes will appear on the screen:

Code	Meaning
2	Throttle problem
4	Motor problem
5	Brake problem

I. Using the anti-theft device

At the bottom of the stem is a built-in anti-theft device in the form of a steel cable that can be locked with a numerical code. This lock is a low security lock and is intended for use as a visual deterrent only.

1. Locking head
2. Anti-theft cable

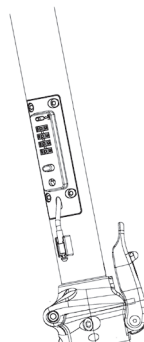

3. Anti-theft cable storage space
4. Lock
5. Locking button
6. Dials
7. Code reset button

The default anti-theft device unlock code is: 0-0-0-0

1. Unlock the anti-theft device (default code 0000)
2. Slide the reset button to the right (SET mode)
3. Set a new code by turning the dials
4. Slide the reset button to the left

To attach the scooter to a fixed support:

1. Pull on the anti-theft cable
2. Press the unlock button
3. Insert the cable head in the lock
4. Turn the dials to lock the anti-theft device

To remove the scooter from a fixed support:

1. Enter the safety code
2. Press the unlock button
3. Pull the cable out of the lock
4. Stow the cable in the stem tube

After use, to store the cable, push up on the cable of the anti-theft device into the stem tube and secure the cable head in the storage bracket to prevent it from hanging down and getting caught in the wheel.

E. Instructions for use

Your experience in riding bicycles, driving cars, skiing and other similar means of transportation can be applied to our products and help you better handle your Carrera impel is-2.

- Before each trip, check that the tyres are not damaged and that no screws on the Carrera impel is-2 are loose. If you notice anything unusual, contact your local retailer.
- Fully charge the battery of the Carrera impel is-2 before using it for the first time
- Do not make any changes to the parts of the Carrera impel is-2, as this may reduce its performance, damage it, and potentially cause serious injury.
- Always ride with your Carrera impel is-2 with the lights on.
- Always look in the direction where you are going: a clear view will help you to ride your Carrera impel is-2 safely.
- Do not ride on wet roads or in bad weather. This could result in loss of traction and cause personal injury and property damage.
- Adjust your speed to suit your environment so that you can stop the Carrera impel is-2 at any moment.
- When riding with other people, maintain a safe distance of at least 2 metres from each other to avoid collisions.
- Operating the scooter under the influence of alcohol and/or drugs is prohibited.
- Always keep your hands on the handlebars when using the Carrera impel is-2 Using a smartphone or any other object while riding is prohibited. Stay focused while riding your Carrera impel is-2: other activities such as making phone calls or listening to music are prohibited.
- It is strongly recommended that you wear adequate protection when using the Carrera impel is-2 to avoid personal injury in the event of a fall: shoes, helmet, gloves, knee pads, elbow pads.
- Avoid riding on roads with debris such as branches, rubbish or gravel.
- Avoid riding on unpaved roads or in areas with obstacles.
- Jumping over obstacles is prohibited. It is important to anticipate and adapt your trajectory and speed to those of a pedestrian before crossing these obstacles. It is also recommended to get off the scooter when these obstacles become dangerous due to their shape, height or the risk of skidding.
- Do not ride your Carrera impel is-2 on slippery roads where there is a risk of loss of traction such as snow, ice or water.
- Do not jump over obstacles with the Carrera impel is-2 scooter.
- Always keep your feet on the deck when riding. Do not jump on the deck.

- Remember that you can injure yourself by losing control, colliding or falling off the Carrera impel is-2.
- Do not use the Carrera impel is-2 in an unsafe environment where flammable products, vapours, liquids, dust or fibres may be present and cause a fire or explosion.
- It is prohibited to mount a seat on the electric scooter for use in a seated position.

I. User weight limit

- Main reasons for weight limit:
 1. Guarantee the user's safety.
 2. Avoid damaging the Carrera impel is-2 due to overloading.
- The maximum weight supported by the Carrera impel is-2 is 120 kg
- The weight of the user and his/her belongings must not exceed the maximum weight indicated in this manual. Overloading may cause the user to fall or be injured and may damage the Carrera impel is-2. In addition, the weight of the user must not be less than the minimum weight of 20 kg. Failure to comply with the recommendations may result in the Carrera impel is-2 losing its ability to safely decelerate or stop while going downhill.
- It is forbidden for more than one person to ride the scooter. The Carrera impel is-2 is designed to be ridden by one person only.

II. Maximum travel distance

The maximum travel distance varies depending on several factors, such as:

- Terrain: Smooth, flat terrain increases the travel distance. Sloping terrain reduces the distance.
- Avoid driving on steep slopes.
- User weight: The user weight affects the distance travelled.
- Ambient temperature: Storing and using the Carrera impel is-2 at the recommended temperature may increase the travel distance; using the Carrera impel is-2 outside of this temperature range reduces the travel distance.
- Speed and driving habits: Consistent, low operating speed increases the driving distance; conversely, frequent starting, stopping, accelerating and decelerating reduces the driving distance.
- Do not start and stop suddenly.
- Do not use the Carrera impel is-2 on slopes that are too steep. Accelerating on too steep a slope can cause the engine and battery to overheat.
- When the battery is charged, the typical range in average conditions is 20km [12.4 mile].

F. Cruise Control

- To enable the cruise control feature:
 1. Hold the throttle in the same position for 6 seconds
 2. The speedometer icon will light up to show it is active



- To disable cruise control, either:
 1. Press on a brake lever or
 2. Tap on the throttle

G. Speed Alarm

- The electric scooter is fitted with a speed alarm to warn you that you may be going too fast when riding down a hill, this function operates when the speed of the scooter exceeds 30 km/h [18.5 mile/h].
- Please pay special attention to the beeps as travelling at this speed or greater may result in loss of control and an increase chance of injury.

H. Using the charger

Before charging the battery, please also note the following points regarding the battery charger:

- Follow the instructions on the battery charger label.
- Do not use this charger near explosive gases or corrosive substances.
- Do not shake or hit the charger or allow it to fall.
- Always protect the charger from rain and moisture for indoor use.
- The operating temperature range of this charger is between 0 and 40°C.
- It is forbidden to disassemble the charger. In the event of a problem, have the unit repaired by a qualified service technician.
- Only use the charger supplied with your electric scooter to avoid damaging it. Please note that failure to do so will void the warranty.
- When charging, the battery and charger should be at least 10 cm away from the wall and in a dry, well-ventilated place. Do not place anything in the direct vicinity of the charger during use.
- Avoid prolonged contact with the charger while charging (risk of superficial burns).
- Do not place the charger in an unstable position.
- Do not cover the charger to avoid overheating while charging.
- Do not immerse the product
- Avoid any contact with water while recharging the battery. Do not touch the charger with wet hands.
- Do not use the charger with a damaged power cord or plugs. Make sure that the charger plug is properly connected to the mains when charging.
- Do not short-circuit the charger pins using a metal object.
- Disconnect the power before connecting or disconnecting the battery connections.
- This charger is designed to charge lithium batteries, do not use it to charge anything other than this electric scooter, only use the specific Carrera battery charger with this electric scooter
- This scooter may only be used by people aged 14 years or older. People with diminished physical, sensory or mental capabilities or lacking experience or knowledge, must be supervised and understand the risks.
- The unit must not be cleaned or maintained by anyone under 14 years of age.
- Children should be supervised to ensure that they do not play with the device.
- Keep out of reach of children, this product is not a toy.
- The electrical outlet to which the device is connected must be installed near the equipment and must always be easily accessible. Do not step on the charger or cable.
- The external flexible cable of this product cannot be replaced; If the cord is damaged, the product should be discarded.
- At the end of its service life, bring the product to a recycling centre.

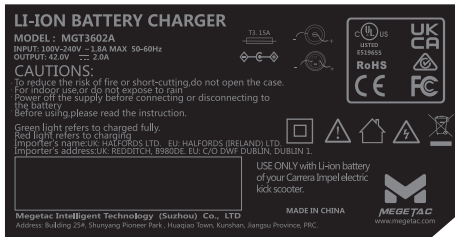

means that this structure uses double insulated or reinforced insulation for class II products



means that the product must be used indoors



means that the device must not be disposed of with household waste (2012/19/EU). It must be recycled.

Charger

Input voltage: 100-240 V

Output voltage: 42 V

I. Charging procedure

Please charge the battery of the electric scooter as follows:

- The battery can be recharged using a standard power outlet.
- 1. Insert the charger plug into the scooter battery (charging connector) by lifting the silicone cap that covers the charging connector on the front right side of the deck.
- Check that the charging connector is dry and plug the charger's power cable into a nearby mains socket.
- When charging, the LED on the charger will turn red to indicate proper operation. When it turns green, it means that the battery is charged.
- To complete charging, you must unplug the mains plug and then the plug connected to the battery. Finally, close the battery socket cap.
- Unplug the mains plug.

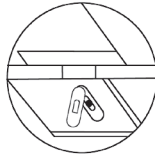
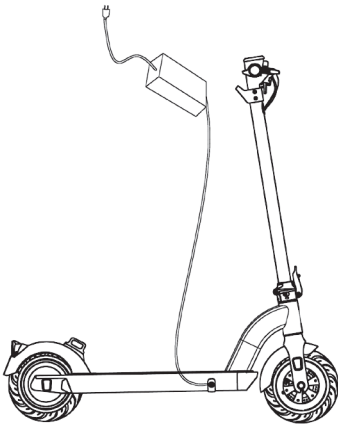

Lift the rubber cover

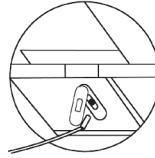

Plug the power adapter into the charging port.

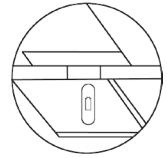

When charging is complete, replace the rubber cover

IMPORTANT:

- Charging for too long may shorten battery life. Do not leave your Carrera impel is-2 connected to the charger overnight.
- Make sure to fully charge your Carrera impel is-2 battery the first time and everytime you charge it to maximise its service life.
- Charge in a clean and dry environment.
- Do not charge the battery if the charging plug is wet.

J. Battery

This electric scooter is equipped with a high-quality Li-ion battery. The Li-ion batteries have no memory effect and a wide temperature tolerance range from -10 to 40°C. The battery is placed in a compartment under the scooter's deck.

To ensure maximum battery life and to protect the battery from damage, please follow the use and care instructions below.

I. Battery life

After charging your battery, it is advisable to let it rest for 20 to 30 minutes before use.

The operating life of your battery depends on several factors:

- The choice of the mode of assistance
- The weight of the user
- The gradient (slope)
- Tyre inflation
- The wind
- Starting and stopping frequency
- Outdoor temperature

II. Warning, precautions

It is recommended to recharge the batteries on a regular basis, or after each use. There is no memory effect on this battery.

To maximise the service life of your battery, it is recommended:

- Avoid very hot and very cold places (ideal charging temperature 20°C)
- Allow the battery to cool down 30 minutes after use.
- If the Carrera impel is-2 stops due to overheating, place the Carrera impel is-2 in a cool, dry place and wait for the battery and hub motor to cool before using it again.



Precautions for use:

Use only the specific charger supplied to charge the battery. Do not use any power supply or electrical device other than the one supplied with the device.

WARNING

- Only charge the battery in a well-ventilated area.
- Do not expose the battery to heat or charge it in direct sunlight.
- Do not disassemble or modify the battery case built into the footboard compartment of the electric scooter.
- Do not connect the (+) and (-) connections of the battery plug with a metal object.
- Do not expose the battery to liquids.
- Do not use a damaged battery.
- Do not continue to charge the battery if it is not fully charged after the theoretical charging time; 5.5~6 hours
- Do not use the battery if it emits an unusual smell or becomes unusually hot.
- Keep the battery out of the reach of children.
- Recharge your battery before prolonged storage and perform the same operation after storage.
- Do not leave the battery charging for an extended period without attention.

III. Battery service life

The battery service life depends largely on the use you make of it. Do not expose the battery to temperatures lower than -10°C or higher than 40°C. Doing so may affect its operation.

Batteries can suffer from ageing of their performance after numerous charges. This will depend on usage habits.

Once the product is no longer in use, dispose of the device in accordance with local recycling processes. For additional information, contact your local authorities or your local retailer.

IV. Using the battery

To ensure maximum battery life and to protect the battery from damage, please follow the use and care instructions below:

When you notice that the charge drops to 25% (or ¼ of the maximum charge), the battery should be recharged quickly.

When the battery icon on the display appears empty and flashes, it means that the voltage is low and the Carrera impel is-2 scooter will not have enough power to operate normally. Stop as this may cause instability in the battery exchanges and thus reduce the battery service life.

WARNING: Do not use the Carrera impel is-2 when the battery is low or the system requires a safe shutdown. Battery service life will be shortened if you continue to use the Carrera impel is-2 while the battery voltage is low.



WARNING

WARNING: Battery service life may be shortened if stored for long periods without being periodically recharged as mentioned above.

- Do not use any metal to directly connect two poles of the battery, as this may cause a short circuit.
- Never place the battery near a fireplace or any other heat source.
- Do not shake the battery, do not drop the battery.
- If the battery pack is removed from the scooter, keep it out of the reach of children to prevent accidents.
- Do not attempt to disassemble the scooter to access the battery. Do not open the battery.
- If the battery leaks, be careful not to let the liquid come into contact with your skin or eyes. If this happens, wash with plenty of water and seek medical attention.

Battery Specifications

Type	Lithium-ion
Nominal voltage	36 V
Capacity	13 Ah
Charging time	5.5~6 hours
Number of cycles ($\geq 70\%$ capacity)	500 cycles
Input voltage	100-240 V

K. Recycling

Disposal instructions for users:

Once no longer in use, dispose of the device in accordance with local recycling processes. For additional information, contact your local authorities or retailer.

L. Cleaning, maintenance and storage

The Carrera impel is-2 requires regular maintenance. This section describes the important steps and requirements associated with maintaining your Carrera impel is-2.

I. Cleaning

- Ensure the power supply and charging cable for the Carrera impel is-2 have been properly disconnected.
- Wipe your Carrera impel is-2 clean using a soft, damp cloth.



WARNING:

- Your Carrera impel is-2 is certified IPX5. However, it should not be immersed in liquid or subjected to a water jet. Never clean the Carrera impel is-2 with high-pressure water jets / pressure washer and never submerge it in liquid.
- Do not allow water or other liquids to enter the Carrera impel is-2 as this may cause irreversible damage to the electronic components.
- If you do, your warranty will be voided.
- Cleaning and maintenance of the device should not be performed by anyone under the age of 14.

II. Maintenance

Wheel and brake system maintenance:

- Remember to apply lubricating oil regularly to both ends of the brake cable to ensure long service life and proper operation.
- Carefully check the front and rear wheels and hub before using the scooter. The tyres must not be damaged or punctured.
- In case of a problem, contact your local retailer to replace the tyres and if needed the inner tubes. The inner tubes must be deflated before disassembling/separating the wheel rim.
- Hardware maintenance:
Carefully check the bolts on each part before using the scooter. The bolts must not be loose or damaged.

Note: Check that the scooter operates normally before each use. In the event of an anomaly, do not use the scooter and contact your retailer for service and repairs. Never modify the structure of the scooter. Any modification may result in injury, and the manufacturer will not be liable for any consequential damage resulting from such modifications.

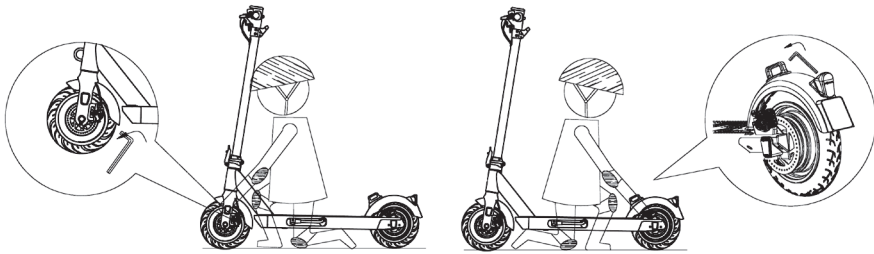

III. Storage

- Before storing it, fully charge your Carrera impel is-2 to prevent over-discharging of the battery due to a prolonged period of non-use.
- Do not charge the battery if the temperature is below 0°C; place the Carrera impel is-2 in a warmer environment (more than 5°C) before charging.
- You must protect your Carrera impel is-2 from any loss in performance due to dust.
- Store your Carrera impel is-2 indoors in a dry place at room temperature (20°C).



WARNING

WARNING: To ensure your safety, never disassemble the Carrera impel is-2 or your warranty will be void.

RECOMMENDATION: If the scooter is not used frequently over a period of time, it should be fully charged every 60 days. The scooter should be stored in a dry, sheltered place at a temperature between 5 and 35°C. Otherwise, the warranty will not apply for such negligence.

M. Technical Specifications

Name	Parameters
Net weight	20 kg
Minimum load	20 kg
Maximum load	120 kg
Maximum speed	approx. 25 km/h [15.5 mile/h]
Maximum range	Up to approx. 35 km [21.8 mile] (depending on terrain, driving habits, rider weight, etc.)
Power source	Lithium-ion battery
Max continuous rated power	350 W
Peak power	575 W
Dimensions (L x W x H)	114 x 47 x 123 cm
Battery	36 V/13 Ah
Operating temperature	Min=0°C, Max=40°C
Maximum tyre pressure	50 PSI/3.45 Bar

N. Scope of Warranty

In case of problems:

- The supplier warranty is valid for normal product use as defined in the user manual for a period of 2 years concerning the product and 1 year for the battery.
- Damages due to a cause unrelated to the device are excluded from this warranty.

- In particular, the warranty does not apply if the device has been damaged by an impact or fall, incorrect operation, non-compliant connection, lightning, mains overvoltage, insufficient protection against heat, humidity or frost.
- The warranty does not cover the user manual.
- The warranty does not cover normal wear and tear of the product (tyres, brake cable and sheath, brake pad, wear of the footboard, wear of the mudguard, wear of the plastic protective covers, etc.).
- The warranty does not cover any deterioration of the product due to misuse, including but not limited to those caused by collisions with objects or falls.
- The warranty does not cover any use of the product that does not comply with the precautions for use stipulated in the user manual.
- The warranty does not cover defects caused to the product by an accessory not supplied.
- The warranty does not cover any damage to the battery.
- The warranty does not cover the product or its accessories if it has been disassembled or modified in any way.
- The warranty does not cover any product not identifiable by its serial number. If parts have been removed, erased, altered or made illegible, the warranty does not apply.
- The warranty does not cover damage to the product as a result of exposure to moisture, extreme heat or cold, corrosion, oxidation, or exposure to any liquid whatsoever.
- The warranty does not cover any deformation, damage, or breakage of the main frame as a result of a sudden fall, excessive overload, or repeated shocks.



Information on Waste Disposal for Consumers of Electrical & Electronic Equipment

This mark on a product and/or accompanying documents indicates that when it is to be disposed, it must be treated as Waste Electrical & Electronic Equipment (WEEE).

Any WEEE marked waste products must not be mixed with general household waste, but kept separate for the treatment, recovery and recycling of the materials used.

For proper treatment, recovery and recycling; please take all WEEE marked waste to your Local Authority Civic waste site, where it will be accepted free of charge.

If all consumers dispose of Waste Electrical & Electronic Equipment correctly, they will be helping to save valuable resources and preventing any potential negative effects upon human health and the environment, of any hazardous materials that the waste may contain.



Please recycle your spent batteries.

Batteries should not be disposed of in unsorted municipal waste, but separately collected to facilitate the correct treatment and recycling of the substances they contain. The recycling of batteries ensures the recovery of these valuable materials and prevents any potentially harmful effects upon both the environment and human health.

Please contribute to battery recycling by segregating all spent batteries and actively participating in their collection and recycling. Various battery collection schemes will be in operation in different areas of the country. However, battery collection bins will be available at retail stores that sell batteries as well as at schools, libraries and other public buildings.



WARNING! Protective equipment should be worn.

To avoid serious injury, always wear protective equipment: shoes, helmet, gloves, knee pads, elbow pads and wrist protectors.



Warning; Explosive material

EU Declaration of Conformity



The equipment which accompanies this declaration is in conformity with the following EU Directives:

GENERAL PRODUCT SAFETY DIRECTIVE (2001/95/EC)
MACHINERY DIRECTIVE (MD) (2006/42/EC)
ELECTROMAGNETIC COMPATIBILITY (EMC) DIRECTIVE (2014/30/EU)
LOW VOLTAGE DIRECTIVE (LVD) (2014/35/EU)
RADIO EQUIPMENT DIRECTIVE (RED) (2014/53/EU)
BATTERY DIRECTIVE (2006/66/EC)
ROHS DIRECTIVE (2011/65/EU) WITH ITS AMENDMENTS COMMISSION
REACH REGULATION (EC NO 1272/2008)

Manufacturer: ZHEJIANG TAOTAO VEHICLES CO.,LTD.
No. 10 Xinyuan Road, Xinbi Street, Jinyun County, Lishui City, Zhejiang Province

Represented in the EU: Halfords Ltd, c/o DWF, Dublin 1.

A copy of the technical file for this equipment is available from the EU address above.

Description of Equipment:

Carrera Impel iS-2, electric scooter, Li-ion battery 36V13AH, 350W motor

The following harmonized standards have been used:

Charger:
EN 60335-2-29:2004+A2+A11
EN 60335-1:2012+A11+A13
EN 62233:2008
EN55014-1:2017
EN55014-2:2015(Category II)
EN6100-3-2:2014, Class A
EN61000-3-3:2013

Other key standards used:

UN38.3; IEC 62133-2:2017, EN 17128: 2020; EN 14619: 2019

Authorised signatures of manufacturer and EU representative

	Manufacturer
Signature:	
Name of signatory:	Chris Hall
Position in company:	Head of Quality
Place and Date:	Dublin Ireland. Oct 2021

UK Declaration of Conformity

The equipment which accompanies this declaration is in conformity with the following UK legislation:



Supply of Machinery (Safety) Regulations 2008
Electrical Equipment (Safety) Regulations 2016
Electromagnetic Compatibility Regulations 2016
Radio Equipment Regulations 2017
The Restriction of the Use of Certain Hazardous Substances in Electrical and Electronic Equipment Regulations 2012

Manufacturer: ZHEJIANG TAOTAO VEHICLES CO.,LTD.
No. 10 Xinyuan Road, Xinbi Street, Jinyun County, Lishui City, Zhejiang Province

Represented in the UK: Halfords Ltd., Redditch, B98 0DE.

A copy of the technical file for this equipment is available from the UK address above.

Description of Equipment:

Carrera Impel iS-2, electric scooter, Li-ion battery 36V13AH, 350W motor

The following harmonized standards have been used:



Charger:

- EN 60335-2-29:2016+A1
- EN 60335-1:2012+A11+A13
- EN 62233:2008
- EN 55014-1:2017
- EN 55014-2:2015(Category II)
- EN 6100-3-2:2014, Class A
- EN 61000-3-3:2013

Other key standards used:

UN38.3; IEC62133-2:2017; EN 17128: 2020; EN 14619: 2019;
EN 62479:2010

Authorized signatures of manufacturer and EU representative

	Manufacturer	UK representative
Signature:		
Name of signatory:	<i>David Shi</i>	<i>Chris Hall</i>
Position in company:	<i>Sales manager</i>	<i>Head of Quality</i>
Place and Date:	<i>Zhejiang P.R.C., Oct. 2021</i>	<i>Redditch UK, Oct. 2021</i>

CONTACT US

Halfords Ltd, B98 0DE.

Produced for Halfords.

www.halfords.com

Item Code: 629110

ROI: Halfords c/o DWF, Dublin 1





*We love seeing your adventures!
Tag **@Carrera_UK** to be featured.*

